



Circular and suspended luminaire, equipped with LED technology.

Housing is made of sheet steel, colour acc. to RAL 9006.

Light is distributed via an opal acrylic cover.

The luminaire can be produced with different diametres, Lumen packages or colours.

Type	Lumen Output	System Power	Dimension (Ø x h)
Ring Star 900 4.5 OS	4.500 Lumen	55 Watt	900 x 80 mm
Ring Star 1240 6.5 OS	6.500 Lumen	79 Watt	1.240 x 80 mm
Ring Star 1540 8.0 OS	8.400 Lumen	103 Watt	1.540 x 80 mm
Ring Star 1900 10.5 OS	10.900 Lumen	134 Watt	1.900 x 80 mm

### Technical Information:

Voltage:	220-240 V / 50-60 Hz
Protection Class:	1
Protection Type:	IP20
Ballast:	switchable
Cover:	opal
Colour:	RAL 9006
Light Colour:	4.000K
CRI:	RA>80

### Dimension Drawing:

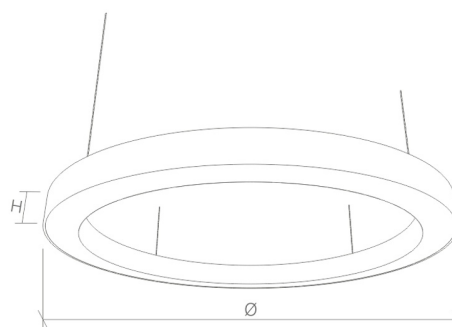

### Options:

- Light Colour 3.000K
- Ballast DALI dimmable
- Housing acc. to RAL Card
- Direct and indirect lighting (h=100 mm)